

Aristo[®] RoboFeed 3004w ELP 12p

The optimum feeding solution for robot applications

Sturdy and reliable

Sturdy design with aluminium casing for reduced weight and ideal for use in tough environments. The digitally controlled feed units perform accurate speed control with the aid of a pulse encoder on speeds ranging from 0.8 to 25.0 m/min*. The 4-roll feed mechanism with grooves in both feed and pressure rolls give stable feeding and low wear of the wire, all of which help to ensure reliable wire feeding. (*Max wire feed speed is 30.0 m/min for Aristo[®] RoboFeed when controlled by U8₂/W8₂ with sw-version from 0,03N or later.)

Aristo[®] RoboFeed 3004w ELP 12p is available with Ø30 mm rollers for wires up to Ø1.6 mm.

Flexibility

Aristo[®] RoboFeed 3004w ELP 12p is a completely enclosed feeding unit which includes the drive control system and the operational functions for gas purge and wire inching, forward and reverse.

The unit is equipped with mounting bolts with rubber absorbers to protect the components from the high acceleration and deceleration forces of the robot.

Aristo[®] U8₂ - The ultimate man-machine communicator for advanced applications. It is the standard operational pendant for Aristo[®] robot packages, consisting of Aristo[®] Mig power sources, Aristo[®] RoboFeed interconnection cables, wire conduits and Aristo[®] RT robotic torch.

With safety in mind

Designed to meet the most rigid safety standard IEC 60974-5 with low voltage (42 V/AC) operations and overload protection circuit to eliminate breakdowns.

Applications

- Robot applications within the automotive industry and other applications requiring a small size, low weight feeder with an excellent wire feeding performances



Easy service and maintenance

The feeder mechanism is easy to access and all wear parts can be exchanged without tools. One single pressure device makes it easy to adjust the appropriate feeding pressure. All electronic components are protected in a separate compartment.

- The Aristo[®] robot package offers more than 200 pre-programmed synergic lines as well as memory for 255 parameters or schedules
- Easy to connect/disconnect by using quick connectors for gas, liquid, control signals and welding current
- TrueArcVoltage™ system for continuous measurement of the arc length
- All control functions at the front of the feeder or accessible via Aristo[®] U8₂ or external control panels
- CAN-Bus for internal communication between the components
- Detects anti-collision through the CAN-Bus
- Forward and reverse wire feed inching
- Shielding and cleaning gas purge

Technical data

Power supply, Vac, Hz	42, 50/60
Drive mechanism	4 WD
Drive rollers, mm	30
Wire feed speed, m/min	0.8-30.0
Dimensions l x w x h, mm	362 x 246 x 235
Weight, kg	7.3
Speed control	Pulse encoder

Wire dimensions:

steel	0.6-1.6
stainless steel	0.6-1.6
aluminium	1.0-1.6
cored wire	0.8-1.6
Enclosure class	IP 23
Standards	IEC 60974-5



Aristo® RoboFeed (front)



Aristo® RoboFeed (rear)

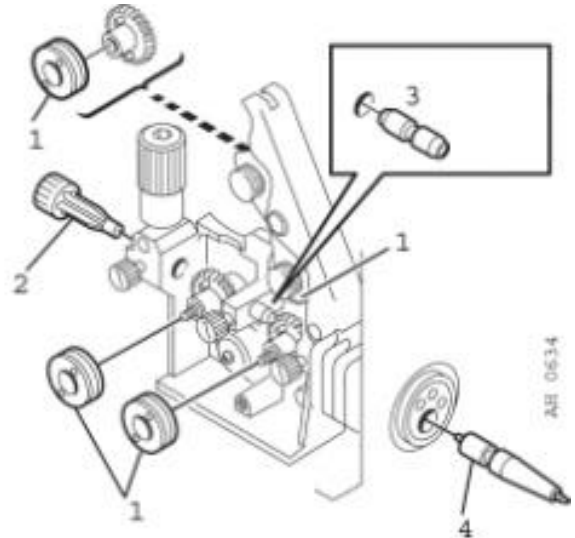

Wear parts 30-4 / 3004

Wire Ø mm	Wire type	1 Feed roller	2 Inlet nozzle	3 Intermediate nozzle	4 Outlet nozzle	Groove type	! Marking
0.6 / 0.8	Fe, Ss, C	459052-001	455049-001	455072-002	469837-880	V	0.6 S2 & 0.8 S2
0.8 / 0.9-1.0	Fe, Ss, C	459052-002	455049-001	455072-002	469837-880	V	0.8 S2 & 1.0 S2
0.9-1.0 / 1.2	Fe, Ss, C	459052-003	455049-001	455072-002	469837-880	V	1.0 S2 & 1.2 S2
1.4 / 1.6	Fe, Ss, C	459052-013	455049-001	455072-002	469837-880	V	1.4 S2 & 1.6 S2
0.9-1.0 / 1.2	C	458825-001	455049-001	455072-002	469837-880	V-K	1.0 R2 & 1.2 R2
1.2 / 1.4	C	458825-002	455049-001	455072-002	469837-880	V-K	1.2 R2 & 1.4 R2
1.6	C	458825-003	455049-001	455072-002	469837-880	V-K	1.6 R2
0.8 / 0.9-1.0	Al	458824-001	455049-001	456615-001	469837-881	U	0.8 A2 & 1.0 A2
1.2 / 1.6	Al	458824-003	455049-001	456615-001	469837-881	U	1.2 A2 & 1.6 A2
C=cored wire						K=knurled groove	

* Bold = Standard

Ordering information

Aristo® RoboFeed 3004w ELP 12p	0461 000 891
Interconnection cable 5.0m air-cooled	0740 538 890
Interconnection cable 10.0m air-cooled	0740 538 881
Interconnection cable 15.0m air-cooled	0740 538 882
Interconnection cable 5.0m water-cooled	0740 538 895
Interconnection cable 10.0m water-cooled	0740 538 886
Interconnection cable 15.0m water-cooled	0740 538 887
Interconnection cable 25.0m water-cooled	0740 538 888
Interconnection cable 35.0m water-cooled	0740 538 889
(For specific connection cables (depending on robot type) see the relevant leaflet)	

Accessories:

Assembly bracket universal	0461 038 880
Quick connector MarathonPac™ *	F102 440 880
Wire conduit 1.8 m	F102 437 881
Wire conduit 3.0 m	F102 437 882
Wire conduit 3.8 m	F102 437 889
Wire conduit 4.5 m	F102 437 883
Wire conduit 6.0 m	F102 437 887
Wire conduit 6.5 m	F102 437 890
Wire conduit 8.0 m	F102 437 884
Wire conduit 12.0 m	F102 437 885

* Inclusive with RoboFeed

Unrivalled service and support

Our commitment and ability to deliver the expected service and support starts immediately after the order is confirmed. We endeavour to offer our customers an After Sales service, which is second to none. A strong and skilful service organisation is prepared to offer service and maintenance, calibration, validation and upgrading of equipment and software.

The service organisation will offer standardised solutions for the reconditioning or modification of existing products.

Spare and wear parts are manufactured according to ESAB's quality plan. Exchange Printed Circuit Board (PCB), exchange modules and components are available for all our products in order to reduce downtime to an absolute minimum. ESAB is continuously upgrading authorised service partners for local service support. Customers who have their own service and maintenance personnel will always be offered a service-training package as part of a total ESAB offering. However, product and process training for end-users will form an additional part of the ESAB offering. Always ask your ESAB sales representative or distributor for a complete ESAB solution.

Quality accessories for the quality welder

ESAB offers a wide range of accessories. The complete range, along with product information, is available at our local web-sites, look at www.esab.com or contact your local ESAB dealer.



www.esab.com